

Manual

Connect Smart Deadbolt with Fingerprint (CSH-DEDBLTBIO)



WHAT'S INCLUDED

- 1 x Deadbolt Lock Set
- 1 x Manual
- 2 x Keys
- 1 x Hole Cutout Guide
- 1 x Latch
- 1 x Screwdriver
- 1 x Bag of Screws
- 1 x Lock Catch
- 1 x Installation Rubber
- 2 x Smart Keycard

1 | SETTING UP THE LOCK

KEYPAD FUNCTIONS

- Touch the fingerprint reader to activate the screen
- Press * to EXIT / BACK
- Press # to CONFIRM after typing passcodes

MENU

- Long press # then type in super admin passcode (default = 666888) then # to enter Menu System will exit automatically if no operation within 8 seconds

DEFAULT SUPER ADMINISTRATOR PASSCODE

- Factory super admin passcode is: 666888
- To Modify the super admin passcode long press *
- Verify the administrator (type in super admin passcode - 666888 default) then #
- Next enter new admin passcode (must be 6 - 12 digits) then # to confirm or * to exit

ADD ADMINISTRATOR

- Touch the fingerprint reader to activate the screen
- Long press #
- Verify the administrator (type in super admin passcode - 666888 default) then #
- Press 1 > 2
- Type in 6 - 12 digit passcode for new admin user and press # to confirm

TIP

- There are only 3 administrators: ID 0 is Super admin (using 666888 default passcode).
- ID 1 is Smart Keycard admin and ID 2 is Fingerprint admin.
- If admin user is full follow instructions to delete Single User.

ADD NORMAL USER

- Touch the fingerprint reader to activate the screen
- Long press #
- Verify the administrator (type in super admin passcode - 666888 default) then #
- Press > 1 > 1 > 1
- You will be prompted to add a passcode, keycard or fingerprint
- **Adding Passcode:**
Passcode needs to be 6 digits and will need to be input 2 times to confirm
- **Adding a Keycard:**
Place the Keycard on the screen to add
- **Adding Fingerprints:**
Place finger on fingerprint scanner above the numberpad. The fingerprint will need to be confirmed 3 times

TIP

If user is full follow instructions to delete Single User.

ADD ONE-TIME USER

- Touch the fingerprint reader to activate the screen
- Long press #
- Verify the administrator (type in super admin passcode - 666888 default) then #
- Press 1 > Press 1 > Press 2
- Type in 6 - 12 digit Passcode and press # (input 2 times to confirm)

DELETE SINGLE USER

- Touch the fingerprint reader to activate the screen
- Long press #
- Verify the administrator (type in super admin passcode - 666888 default) then #
- Press 1 > Press 3 > Press 1
- You will need to type in the User's ID number then press # to confirm then # again to delete
E.g. To delete User ID 2: Type 2 then # then # again to delete

DELETE ALL USERS

- Touch the fingerprint reader to activate the screen
- Long press #
- Verify the administrator (type in super admin passcode - 666888 default) then #
- Press 1 > Press 3 > Press 2 then operate according to voice instructions

SINGLE OR DOUBLE USER MODE

- Touch the fingerprint reader to activate the screen
- Long press #
- Verify the administrator (type in super admin passcode - 666888 default) then #
- Press 2 > Press 2
- Then press 1 for Single User Mode (only 1 access type required) or 2 for Double User Mode (this mode will require 2 types of authentication e.g. Passcode + Fingerprint, Keycard + Passcode etc.)

LOCK MODE SETTING

- Touch the fingerprint reader to activate the screen
- Long press #
- Verify the administrator (type in super admin passcode - 666888 default) then #
- Press 2 > Press 2 > Press 3
- Press 1 to enable Manual Lock (Press the # key to enable the lock/deadbolt) or 2 for Auto Lock (Auto Lock will automatically enable the lock/deadbolt after the set time)
- **Note:**
In Auto Lock input value from 1 – 99 to set Auto Lock time

VOICE SETTINGS

- Long press #
- Verify the administrator (type in super admin passcode - 666888 default) then #
- Press 2 > Press 3 > then press either:
1 to Increase voice prompt volume
or
2 to decrease voice prompt volume

2

GET THE APP



QR Code for
Downloading Apps

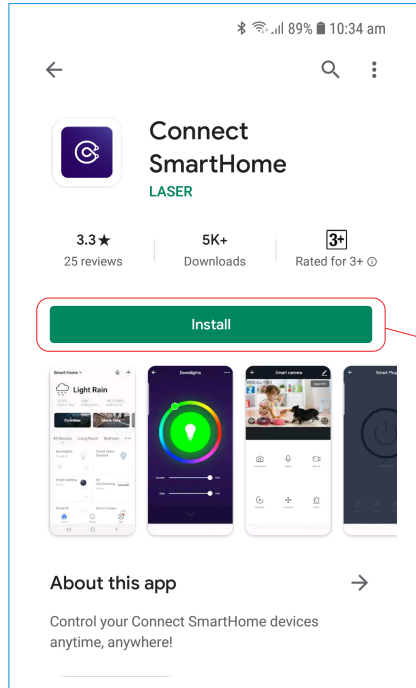

TAP
HERE

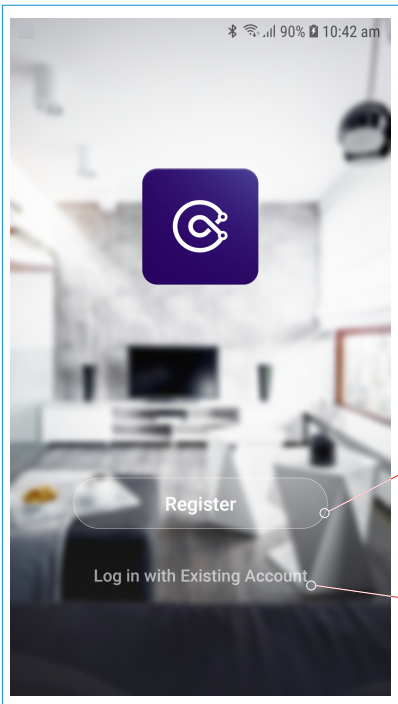

3

REGISTER OR LOGIN TO APP

REGISTER
no
account

LOGIN
existing
account

4 | RECOMMENDED APP SETTINGS

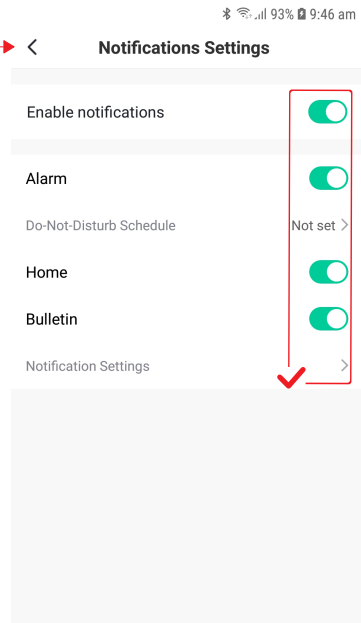
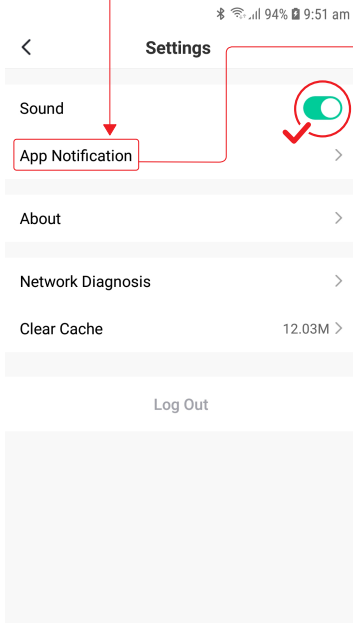
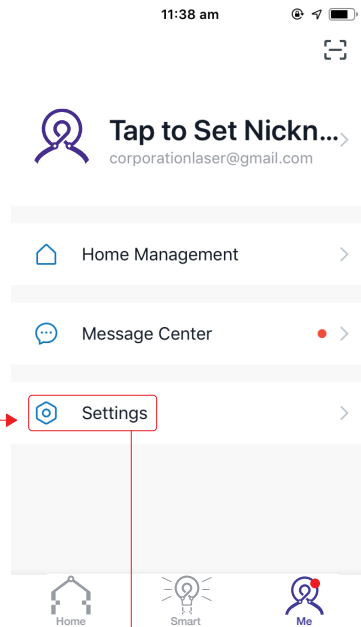
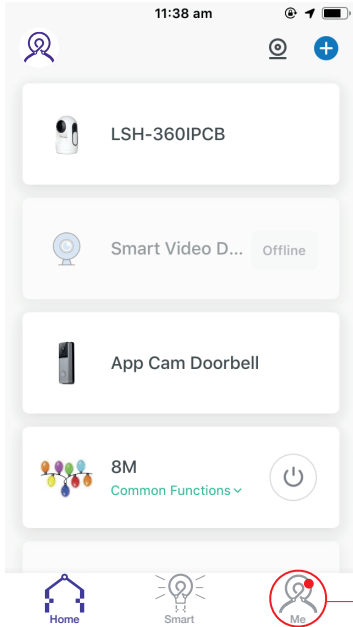

5 | PAIRING LOCK TO APP

- Touch the fingerprint reader to activate the screen
- Long press #
- Verify the administrator (type in super admin passcode - 666888 default) then #
- Select 2 for System Settings
- Select 1 for Network Settings
- Select 1 for Smart Mode or 2 for AP mode (instructions shown are for Smart Mode only)
- The 0 number will start blinking indicating the device is in pairing mode

6 | CONNECTING LOCK TO APP

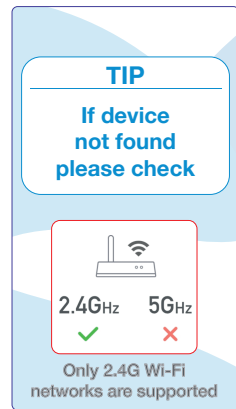
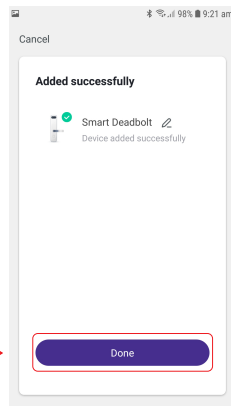
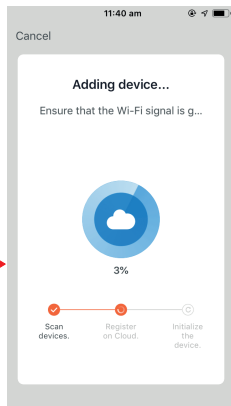
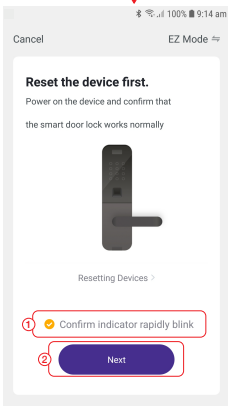
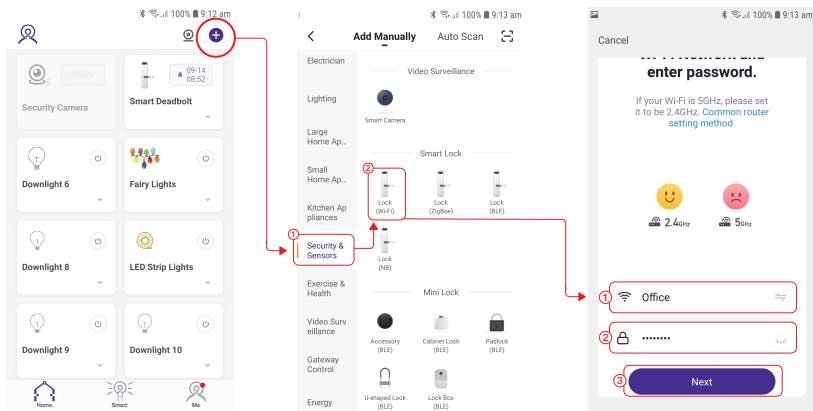

7 USING THE APP

Battery Level

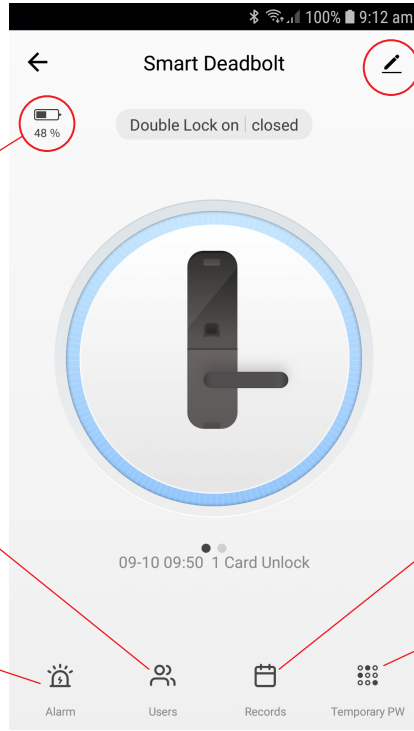

Settings

Registered App users

History

Alarms Triggered

Generate Temporary Passcode

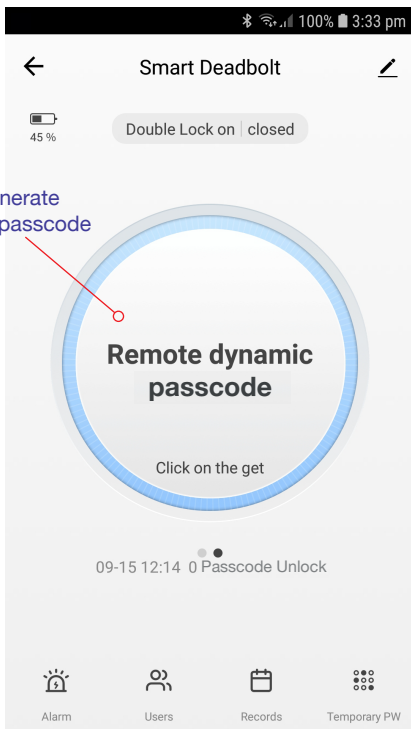

Tap to generate dynamic passcode

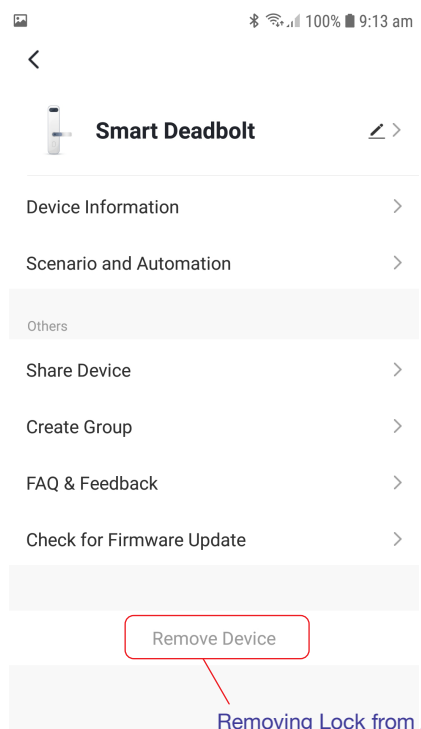

Removing Lock from App

8 | USING THE LOCK

LOCKING

- Touch the fingerprint reader to activate the screen
- Press the # button to engage the lock/deadbolt

PASSCODE UNLOCK

- Touch the fingerprint reader to activate the screen
- Enter the correct passcode and press # to confirm

TIP

To prevent people spying when entering your passcode you can first enter any number, then enter the correct passcode, then enter any number and finally press the # to confirm. For example if the passcode is 666888.

First enter "any number" then 666888 then "any number" then finally # to confirm.

REMOTE UNLOCK REQUEST

- Touch the fingerprint reader to activate the screen
- Press 888 then # to request a remote unlock
- The lock will send a signal to the paired App which will get a notification to remotely unlock (must be actioned within 90s or the request will be cancelled)

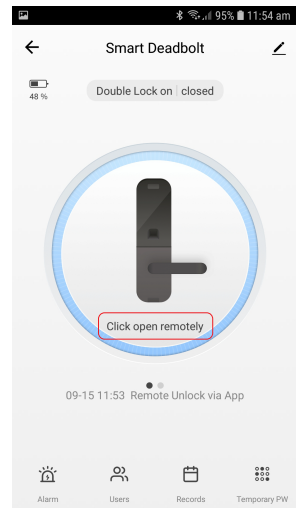

KEYCARD UNLOCK

- Touch the fingerprint reader to activate the screen
- Place keycard over numberpad to unlock

REGULAR KEY UNLOCK

- Remove the knob below the keypad then insert Key into keyhole and rotate 90° to unlock



TIP

Please keep the regular key outside in a safe place in case of product failure or improper operation.

DOUBLE LOCK

- Press button to enable double lock
- During this mode only the Super Administrator can log in

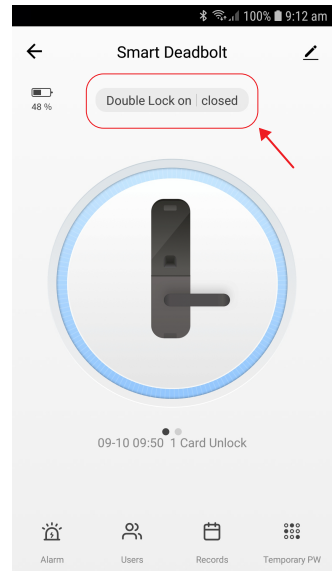

EMERGENCY POWER SUPPLY

Once the battery has exhausted and the lock has no power you can connect an external power source using the Micro USB port under the front panel of the lock. You can then use a passcode or Keycard to unlock the door.



TIP

4 x AA batteries are required to use the lock



ELECTRONIC ANTI-LOCK

- Tap the REST/Anti-Lock button on the bottom right inside the lock body
- There will be a voice prompt and a message notification on the paired App.
- During the anti-lock state only an Admin user or Physical Key can be used.

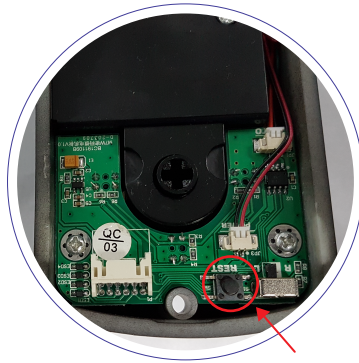

ILLEGAL INTRUSION ALARM

- When a user performs 3 illegal operations, the voice prompts “Illegal invasion, Owner notified” and a short alarm will be activated
- The keypad will be locked for 1 minute and only the Physical Key will work during this time

LOW VOLTAGE ALARM

- There will be low battery alarm if the battery falls lower than 4.6V. The lower digits on the keypad will flash rapidly 5 times and the voice will prompt you to change the battery

TIP

The lock can be unlocked approx 50 more times in this emergency state.

CHANGE LOCK DIRECTION

- Use the toggle switch on the bottom right inside the lock body to change the lock direction from Left to Right or Right to Left:

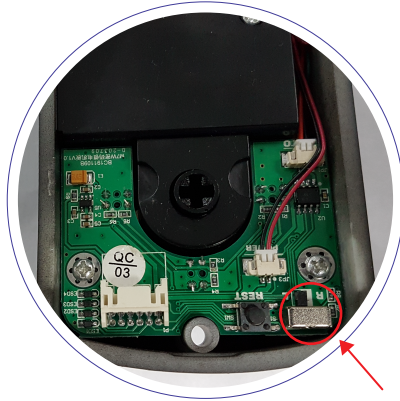

FACTORY RESET

- Press the REST button on the back panel for 3 seconds. Once you hear the voice prompt then the system has reset successfully
- In this state, the admin passcode is reset to 666888, all user data is deleted and the unlock mode is reset to Single open mode.

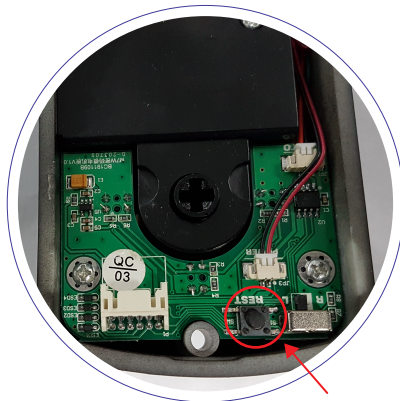

HOLE CUTOUT GUIDE

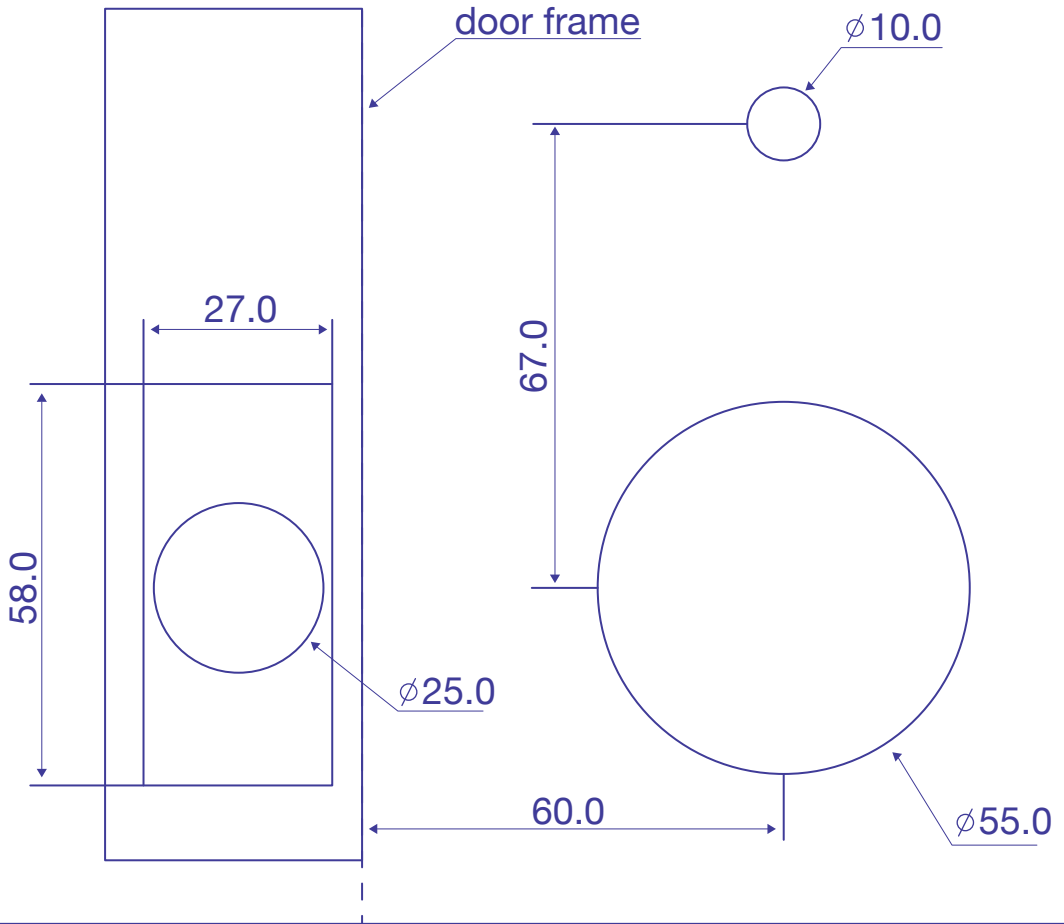

9 | TECHNICAL SPECIFICATION

- Working Voltage: 6V
- Working Current: $\leq 300\text{mA}$
- Static Current: $\leq 30\mu\text{A}$
- Smart Keycard Type: Mifare Card
- Working Temperature: - 20 ~ 60 °C
- User Capacity: Upto 200 users (combinations using passcode, card and fingerprint)
- Fingerprint Capacity: Upto 30
- Super Administrator: 1 user (ID number 0)
- Ordinary Administrator: 2 users (Smart Keycard, App or Fingerprint)
- Temporary User: Upto 10 users (Setup using APP this expires after a short time)
- Dynamic Passcode: 1 user – (Has to be used within: 5 minutes)
- Single User: Upto 5 users
- Unlock Modes: Passcodes, Card, App, Regular Key and Fingerprint
- Passcode combination: 6 - 12 digits
- Number of virtual passcodes: 64
- Suitable door thickness: 35 - 55mm

For more
helpful guides
visit us at



CONNECT

www.youtube.com/channel/UCCYzBiADapJN55Zzp3yfvLQ



WARRANTY

Our goods come with guarantees that cannot be excluded under the Australian Consumer Law. You are entitled to a replacement or refund for a major failure and compensation for any other reasonably foreseeable loss or damage. You are also entitled to have the goods repaired or replaced if the goods fail to be of acceptable quality and the failure does not amount to a major failure.